

## **APPLICATION NOTE FOR THREE PHASE UPS SYSTEMS IN REDUNDANT CONFIGURATION**

This note discusses the application of Nova Jupiter™ Series three phase UPS systems in redundant configuration.

Redundancy of UPS systems can be divided into two types:

- Serial Redundancy (Hot Standby)
- Parallel Redundancy (Active connection)

Nova Electric recommends that the user consider Serial redundancy over Parallel redundancy due to reliability issues.

The possibility of a failure of one UPS while in Parallel Redundancy mode may cause a disturbance of the AC output load. Additionally, If one of the parallel UPS units experiences a failure, it could “drag” the other one down, resulting in the complete loss of AC output to the critical load.

Parallel redundancy requires additional cabinet inter-wiring as a minimum, and in some cases paralleling inductors, resulting in increased floor space and increased cost.

The serial redundancy (Hot Standby) redundant configuration shown in the following diagram consists of two Uninterruptible Power Supply systems with one of the UPSs (UPS 1) connected to the Reserve/Bypass input of the other Uninterruptible Power Supply (UPS 2).

The two Uninterruptible Power Supplies are operating in normal mode and currently under normal conditions. When one of the UPSs experiences a problem, the load will still be afforded full protection from the inverter and the batteries.

If UPS 1 fails and UPS 2 is operating normally, the load is unaffected and is supplied from UPS 2. If UPS 2 was to fail, and UPS1 is operating normally, UPS 2 will transfer the load to UPS 1. The load will then continue to be protected by the inverter and batteries associated with UPS 1.

If both of the UPS systems are running normally, UPS 2 supplies power to the entire load and UPS 1 does not have load. As a result, UPS 1 will have a greater MTBF since it operates at no load. Over a period of time, the functions of UPS1 and UPS 2 can be interchanged if desired.

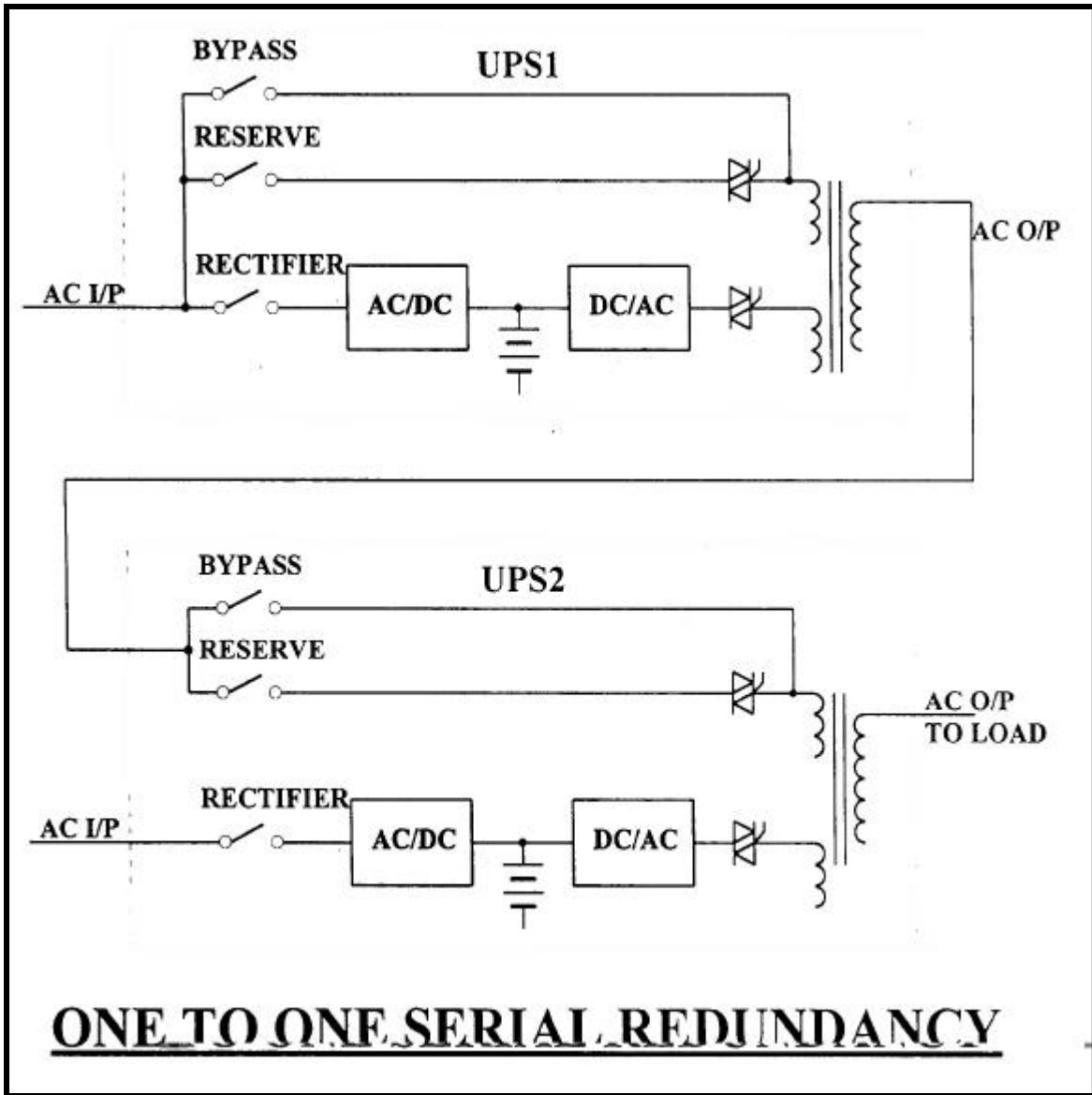

This type of serial redundancy is most often used. As an added feature, when a power failure occurs, the UPS 2 will power the load until the battery is exhausted. At that point, the load will transfer to UPS 1 without any interruption of power to the load and the battery run time will be extended to double the original run time.